

# Profiler™

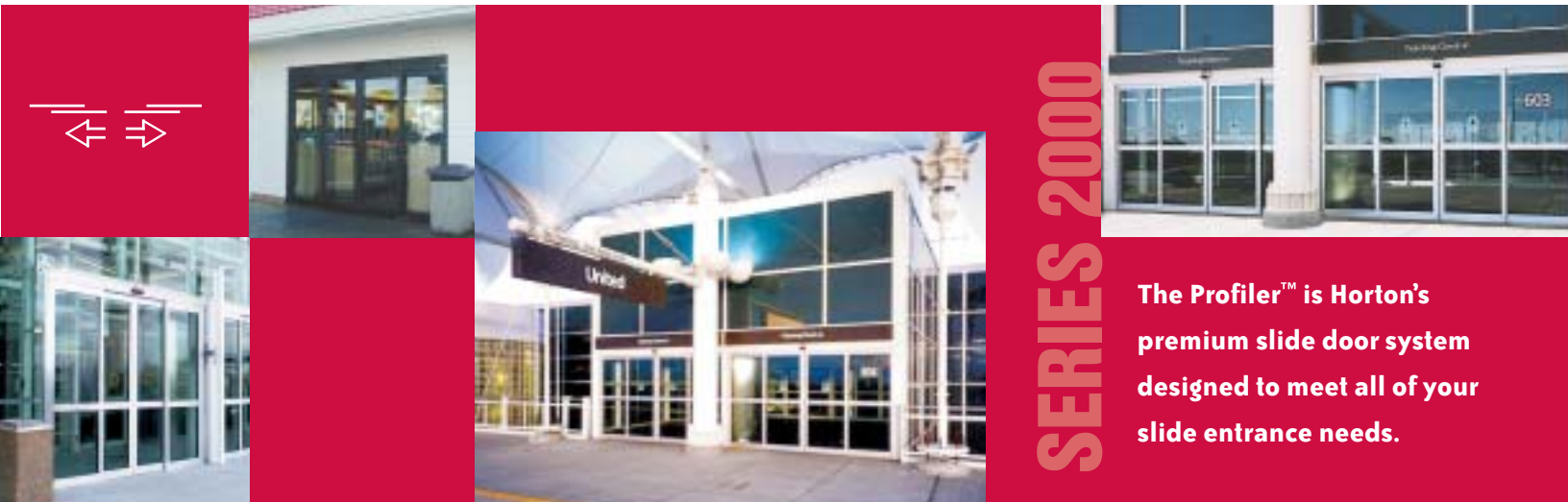

## LINEAR DRIVE SLIDE DOOR SYSTEM



The Profiler™ is Horton's premium slide door system designed to meet all of your slide entrance needs.

### Innovative Features and Economical Performance

The heart of the Profiler™ linear drive system is the simple design of the all-electric, heavy-duty operator. Superior construction, outstanding safety and unsurpassed reliability lead to the lowest cost of ownership in the industry. The emergency breakout mechanism is a heavy duty commercial grade system that is spring loaded for safe opening of heavier doors and owner convenience.

No other door on the market offers the protection of double weather-stripping that is standard in the Horton door package. An adjustable astragal with mohair around the entire perimeter of the door complies with your most rigid infiltration requirements. A partial opening feature is available for seasonal adjustments.

The slim design 4" x 6" header with its smooth face plate blends into your building's architecture.

### Standard Features:

- ▶ Heavy duty slim header design – 4" x 6"
- ▶ Replaceable header track and cap
- ▶ Replaceable bottom guide track and cap
- ▶ Microprocessor control
- ▶ National code approval
- ▶ Linear drive has unique clutch action for added safety
- ▶ 5 year drive train warranty

### Specifier Options:

- ▶ Finish (Anodized aluminum, paint, metal clad)
- ▶ Configuration
- ▶ Overall dimensions
- ▶ Sensor packages
- ▶ Emergency breakout
- ▶ Belt drive system
- ▶ Door panels (Narrow, medium and wide stiles)
- ▶ Muntins and bottom rails
- ▶ Glazing options
- ▶ Electric lock and power fail
- ▶ Panic exit devices

STANDARD PACKAGE DIMENSIONAL DATA

	Unit Width	Maximum Slide Opening	Breakout Opening	
			Type 110	Type 310
Single Slide	7'-0" (2134)	3'-0" (914)	3'-3 1/2" (1003)	6'-3" (1905)
	8'-0" (2438)	3'-6" (1067)	3'-9 1/2" (1156)	7'-3" (2210)
	8'-6" (2591)	3'-9" (1143)	4'-0 1/2" (1232)	7'-9" (2362)
	9'-0" (2743)	4'-0" (1219)	4'-3 1/2" (1308)	8'-3" (2515)
Bi-part	8'-0" (2438)	3'-0" (914)	3'-7" (1092)	6'-9 1/2" (2070)
	9'-0" (2743)	3'-6" (1067)	4'-1" (1245)	7'-9 1/2" (2375)
	10'-0" (3048)	4'-0" (1219)	4'-7" (1397)	8'-9 1/2" (2680)
	12'-0" (3658)	5'-0" (1524)	5'-7" (1702)	10'-9 1/2" (3289)
	14'-0" (4267)	6'-0" (1829)	6'-7" (2007)	12'-9 1/2" (3899)
	16'-0" (4877)	7'-0" (2134)	7'-7" (2311)	14'-9 1/2" (4509)



# Profiler™

Horton Automatics offers the complete door package with custom sizes creating a dependable, economical entrance system. The complete door line is supported by the largest distributor network in the industry.

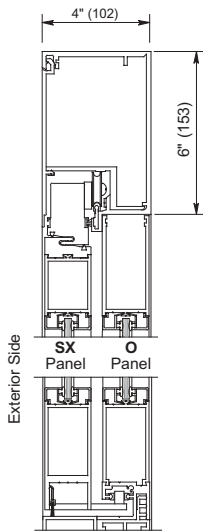

Vertical Section

## Type 110

The sliding panel (SX) slides to the exterior of the fixed sidelite (O) enabling it to swing out from any position of travel.

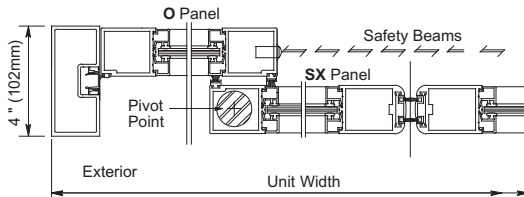

Horizontal Section

7'-0" to 9'-0"  
(2134 - 2743)

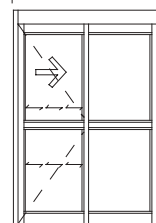

Type SX-O (O-SX Reverse)

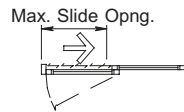

8'-0" to 16'-0"  
(2438 - 4267)

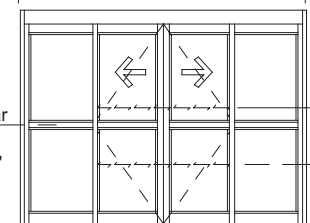

Type O-SX-SX-O

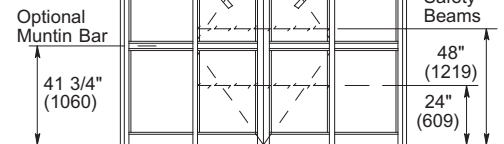

Floor Plans & Elevations

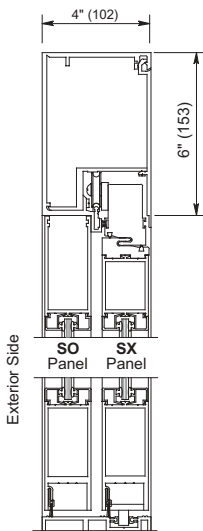

Vertical Section

## Type 310

The sliding panel (SX) slides to the interior of a sidelite (SO) that will swing out.

The combination of both the sliding door and the sidelite swinging out creates a large opening to move wide objects.

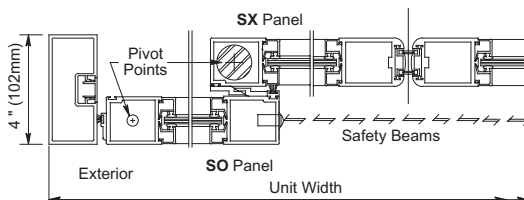

Horizontal Section

7'-0" to 9'-0"  
(2134 - 2743)

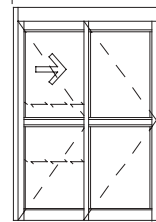

Type SX-SO (SO-SX Reverse)

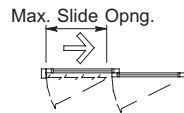

8'-0" to 16'-0"  
(2438 - 4267)

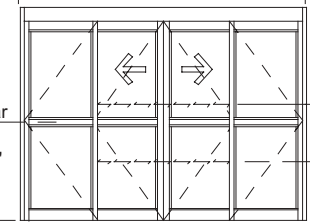

Type SO-SX-SX-SO

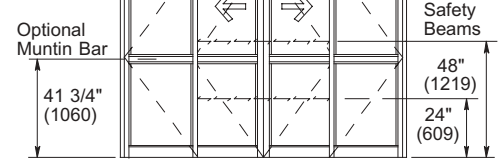

Floor Plans & Elevations



4242 Baldwin Boulevard  
Corpus Christi,  
Texas, U.S.A. 78405-3399  
Tel: 800-531-3111, 361-888-5591  
Fax: 800-531-3108, 361-888-6510  
[www.hortondoors.com](http://www.hortondoors.com)

**Horton Automatics, Ltd.**  
Unit A, Hortonwood 31  
Telford, Shropshire, England TF1-7YZ  
Tel: 01952 670169, Fax: 0192 670181  
International Tel: ++44-1952-670169  
International Fax: ++44-1952-670181



Form A500, Rev. 5/03  
© 1987 Horton Automatics  
Printed in U.S.A.

Horton Automatics reserves the right to alter its product and specifications without notice.